

Installation Guide for Macintosh

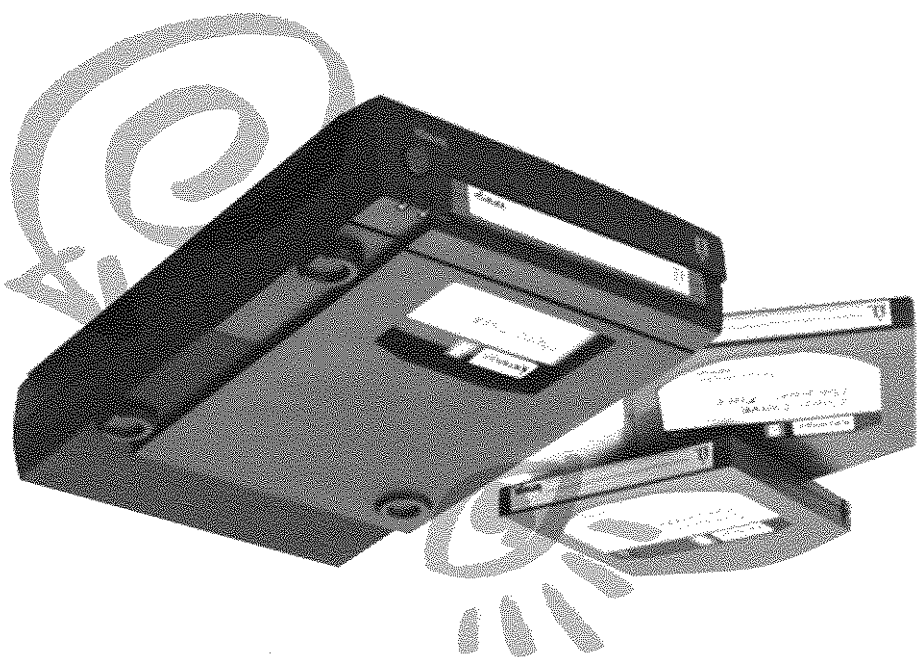

Refer to the electronic manual included with your Jaz software package for a complete list of European support numbers.

European Support Numbers

Omega's technical support associates are ready to take your call Monday through Friday from 6 a.m. to 6 p.m. Mountain time (U.S. & Canada only).

found by Omega to be due to a product defect.

on your phone bill. Either way, the charge will be reversed if your issue is Express, or Discover), or you can call 1-900-988-4747 to put the support cost to charge the support cost to your credit card (VISA, MasterCard, American Express, or Discover). You can call 1-888-4-OMEGA, toll-free, to relate to a defect in an Omega product. Other issues are charged at the rate of One-on-One Technical Support is free of charge for issues Omega determines

One-on-One Omega Technical Support

(No technical support information is available at this number.)

Repair and Return Information 1-801-779-6100

8, N, 1; 9600 baud and above: ANSI (24 hrs - Download only) 1-801-778-5888

Omega Bulletin Board 1-801-778-5888

(Please type "jaz" in the subject header when sending your E-Mail)

Automated E-Mail support@omega.com

Automated FAX Help (U.S. & Canada only) 1-801-778-5763

Microsoft Network GoWord: Omega

America Online™ Keyword: Omega

Internet Home Page: http://www.omega.com

Omega's Automated Help Systems

Canadian DOC Information

This digital apparatus does not exceed the Class B limits for radio noise emissions from digital devices as set out in the Radio Interference Regulations of the Canadian Department of Communications.

United States FCC Information

The computer equipment described in this installation guide generates and uses radio frequency (RF) energy. If the equipment is not installed and operated in strict accordance with the manufacturer's instructions, interference to radio and television reception may result.

Interference This equipment complies with Part 15 of the FCC Rules and its operation is subject to the following conditions: (1) the equipment may not cause harmful interference, and (2) the equipment is subject to the following conditions: (1) the equipment must accept any interference received, including interference that may cause undesired operation.

Part 15, Class B, of the FCC Rules, is designed to provide reasonable protection against radio and television interference in a residential installation. Although the equipment has been tested and found to comply with allowed emission limits, as specified in the above cited Rules, there is no guarantee that interference will not occur in a particular situation. Interference can be determined by turning the equipment off and on while monitoring radio or television reception. The user may be able to eliminate any interference by implementing one or more of the following measures:

- Reorient the affected device and/or its receiving antenna.
- Increase the distance between the affected device and the computer equipment.
- Plug the computer and its peripherals into a different branch circuit from that used by the affected device.

WARNING Only the manufacturer's cable or an equivalent double shielded, host interface cable should be used with external subsystems. Other types of cables may violate FCC rules and regulations. Also, changes or modifications to the electronics or enclosure of this product must be expressly approved by Omega; otherwise, the user's authority to operate the equipment may be voided by the FCC. ■

Installation Guide

This guide shows how to install the portable SCSI Jaz drive on a Macintosh. If you encounter any problems while installing your Jaz drive, refer to the "Troubleshooting" section in the *Jaz User's Guide*.

1 Unpack the Jaz drive and accessories.

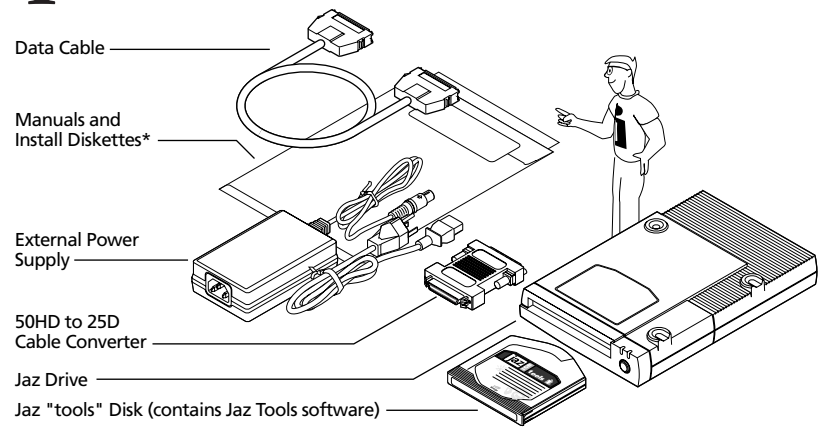

* You will not need an install diskette to install Jaz Tools on your Macintosh.

2 Shut down your Mac, turn off all connected devices, and pick up the Jaz data cable.

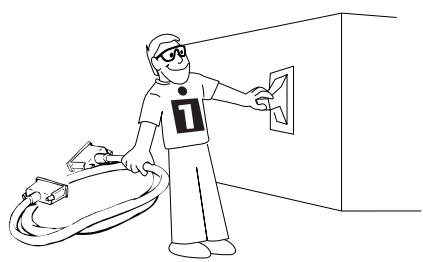

WARNING Always turn off power to the computer and all devices connected to it (such as printers or drives) before beginning any computer hardware change. ■

3 Connect one end of the data cable to either SCSI port on the back of your drive, and PUSH until connector locks into place. (If the connector does not go on easily, try turning it over.)

CAUTION DO NOT attempt to stand the Jaz drive on its side! NEVER move the drive when in use!

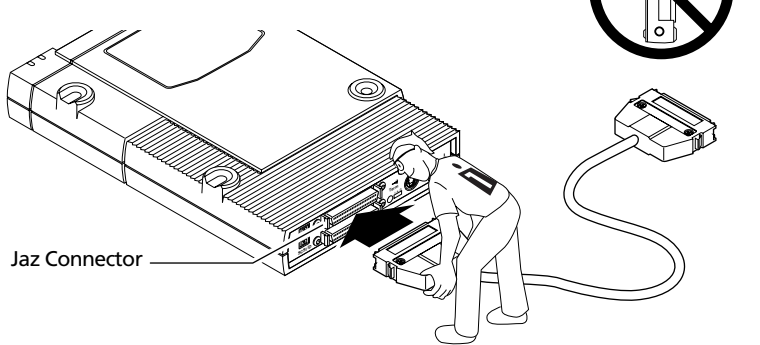

■ **To Remove the Jaz Data Cable:** Squeeze the spring locks on both sides of the data cable connector while pulling on the connector. ■

4 Use the 50HD to 25D cable converter to connect the other end of the data cable to the built-in SCSI connection on your Macintosh.

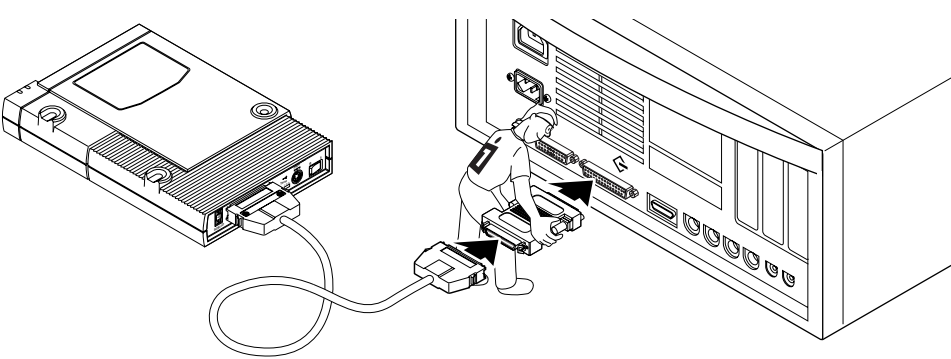

Ⓢ **PowerBook Users** You need a special PowerBook cable to connect the Jaz drive. Check with your Omega dealer or call Omega at 1-800-MY-STUFF to order a Jaz PowerBook cable.

(Open up for Step 5)

5 OPTIONAL: You can connect other SCSI drives to the Jaz drive using another SCSI cable (usually a high density 50 pin to 50 pin cable).

Tip If you are connecting the Jaz drive to an existing SCSI chain, you may need a different cable or converter. Call your Iomega dealer or 1-800-MY-STUFF to order.

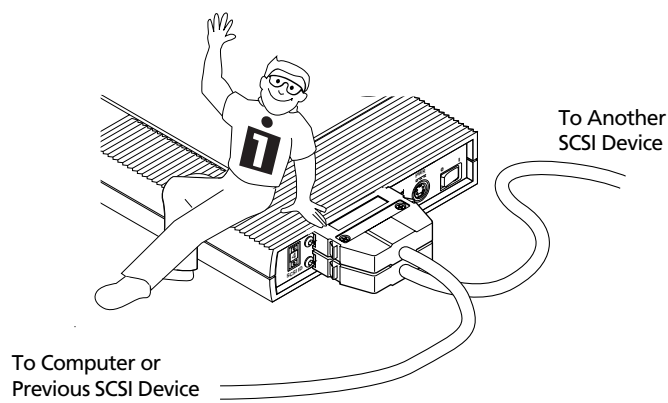

6 Check SCSI IDs if you have a SCSI chain.

Each device in the SCSI chain must have a unique SCSI ID. If you have no other devices, the factory setting of SCSI ID 4 should work. If you need additional information, refer to "SCSI Guidelines" in the *Jaz User's Guide*.

SCSI Termination Your Jaz drive is set to handle SCSI termination automatically. Refer to the *Jaz User's Guide* if you need additional information.

7 Connect the external power supply and turn on the power switch.

CAUTION Use only an approved Iomega Jaz power supply. Other power supplies may damage your Jaz drive.

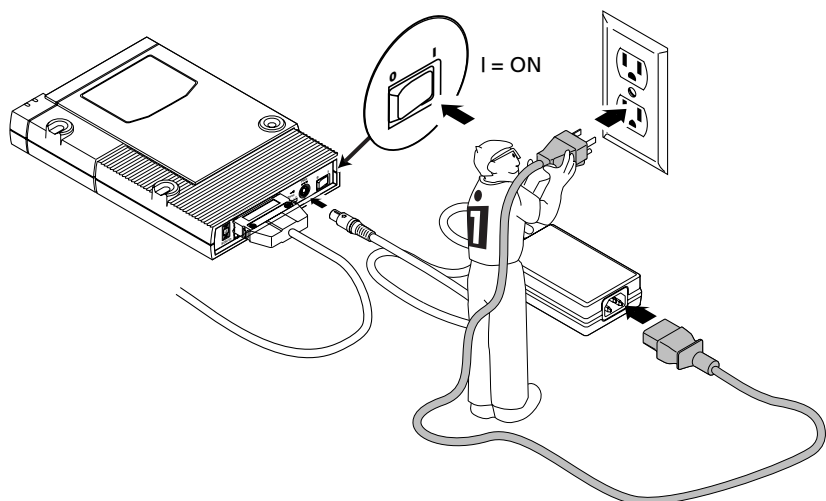

Tip To make it easier to move your Jaz drive between home and work, you may want to purchase an extra power supply and cable. Call 1-800-MY-STUFF to order Jaz accessories.

8 Check that the green power light is ON. (Indicates that the power supply is connected properly.)

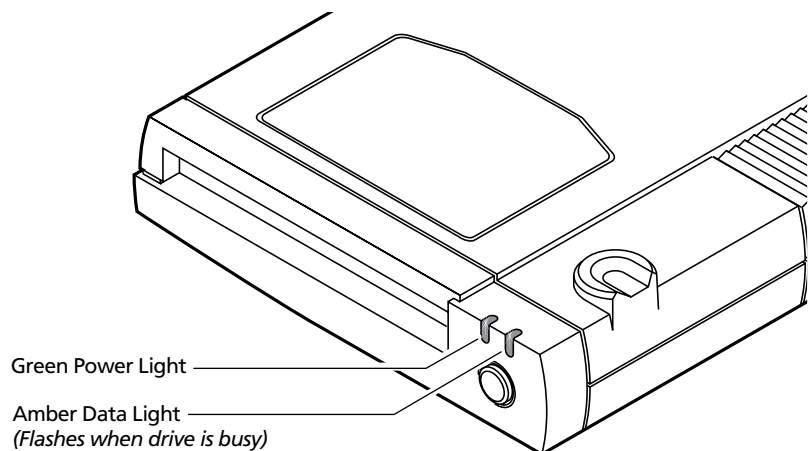

9 Gently insert the 1GB "tools" disk into the Jaz drive.

The amber data light on the Jaz drive flashes as the disk spins up and glows steadily while it acquires. When the amber data light goes out, the drive is ready to use.

CAUTION Never put anything except Jaz disks into the Jaz drive as this could damage your drive. Always keep your Jaz disks free of dust and debris.

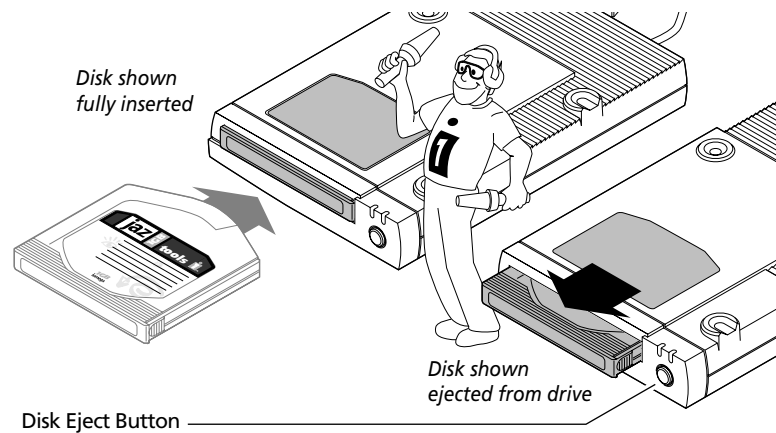

Ejecting Jaz Disks The disk eject button is disabled when the Jaz disk icon appears on the Macintosh Desktop. To eject a Jaz disk from the Desktop, use **Put Away** from the File menu or drag the disk icon to the Trash icon. Note that the drive takes a few seconds to spin down and eject the disk.

10 Start your Macintosh.

Important Make sure the 1GB Jaz "tools" disk is inserted before starting your Macintosh.

11 Double-click on the Iomega Tools disk icon located on your Mac Desktop.



If you do not see the Iomega Tools disk icon on your Mac Desktop, refer to "Troubleshooting" below.

12 Double-click the Iomega Installer icon.



Follow the onscreen instructions to install Tools software for Jaz.

NOTE: If any installation files for the Macintosh Iomega Tools package are deleted from the Tools disk, you will see error messages from Iomega Installer when reinstalling. **DO NOT** change the name of the Jaz "tools" disk or the Iomega Installer will not run correctly.



Congratulations! When the software installation is complete, your Jaz drive will be ready to use.

Use your Jaz drive just like any other drive on your system. Your Jaz disk will appear as an icon on your Mac Desktop. You can store and copy files to and from the Jaz disk using the same methods you use for your Mac hard disk or floppy disks. For more information on using your Jaz drive and Tools software, refer to the *Jaz User's Guide* or to the electronic manuals and help files installed on your Mac hard disk in the Iomega Tools folder.

Tip If you want to use your Jaz drive on a PC as well as your Macintosh: The Guest program on the Install floppy for Windows/DOS will provide temporary access for your Jaz drive on a PC with a SCSI connection. (Use GUEST.EXE on a PC running Windows/DOS; use GUEST95.EXE on a PC running Windows 95.) For full Jaz support, call 1-800-MY-STUFF to order an additional Jaz tools disk.

Troubleshooting

If the Iomega Tools disk icon does not appear on the Mac Desktop, try the following suggestions:

- Make sure the Tools disk is fully inserted in the Jaz drive, then hold down the Shift key and restart your Mac. Make sure you hold down the Shift key until you see the message indicating that extensions are off or disabled.
- If the Iomega Tools disk icon still does not appear, recheck the instructions in this Installation Guide. Make sure the Jaz drive is correctly and securely connected to the Mac.
- If the Jaz drive is part of a SCSI chain, make sure that each device has a unique SCSI ID number (no duplicates) and that the SCSI chain is properly terminated. Refer to the *Jaz User's Guide* for detailed information on SCSI ID and termination.